

-JF-

HSR 200 R

HSR 240 R

Sidevendrive / Rechwender und Zetter

Combined Haymaker / Rateau-faneur combine

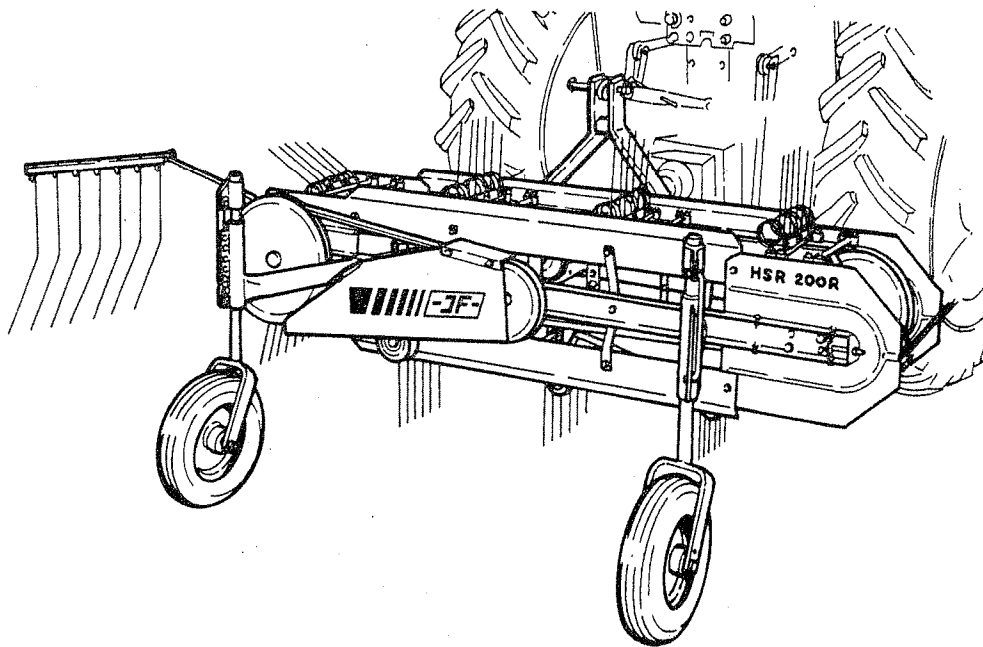
**Reservedelsliste/Ersatzteilliste
Spare Parts List/Liste de pièces****1**

Gyldig fra: November 1987
Gültig ab: November 1987
Valid from: November 1987
Valable à partir de: Novembre 1987

Fabrikationsnr.: 200R: 23127 / 240R: 9813
Maschinen Nr.: 200R: 23127 / 240R: 9813
Serial No.: 200R: 23127 / 240R: 9813
No. de serie: 200R: 23127 / 240R: 9813

Notér nummeret på Deres maskine på omslagets inderside.

Notieren Sie die Nummer Ihrer Maschine auf der Innenseite des Umschlages.

Please note the serial number of Your machine at the inside of the cover.

Veillez noter le numero de Votre machine sur la face interne de la couverture.

Bestiller De reservedele så opgiv venligst maskinens fabrikationsnummer og eventuelt købsår. Det sparer Dem tid, penge og ærgelser og os unødigt besvær.

De kan notere nummeret på Deres maskine her:

Nr. Leveret den / 19
så har De det ved hånden, når De eventuelt skal bestille reservedele.

Fabrikationsnummeret findes indhugget i rammen, som vist på figuren.

Bei Ersatzteilbestellungen ist die Fabrikationsnummer Ihrer Maschine unbedingt anzugeben. Das erspart Ihnen Zeit, Geld und Ärger und erleichtert uns die Abfertigung.

Tragen Sie die Nummer Ihrer Maschine bitte hier ein:

Nr. Geliefert am / 19
dann haben Sie bei Ersatzteilbestellungen immer die Nummer bei der Hand.

Die Fabrikationsnummer ist im Rahmen eingeschlagen, siehe Figur.

Always state the serial number and if possible the year of the machine when ordering spare parts whereby you save time and money and facilitates matters for us.

Please enter the number of your machine here:

No. Delivered on the / 19
Appropriate when ordering parts.

The serial number is located as shown on the figure.

Lorsque vous commandez des pièces détachées, indiquez toujours le numéro de série de votre machine et si possible son année de fabrication. Vous éviterez des pertes de temps et vous nous faciliterez le travail.

Prière de noter ici le numéro de série de votre machine:

Numéro Livrée le / 19
Ceci vous sera utile lorsque vous commanderez des pièces.

Le numéro de série est gravé dans le cadre comme indiqué sur la figure.

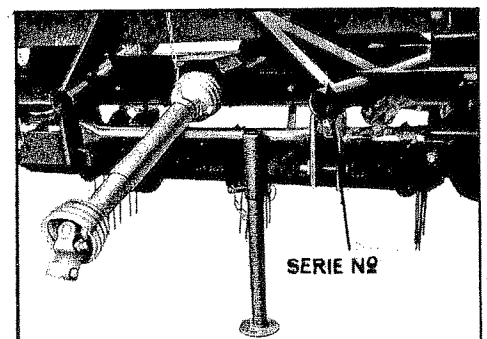



RESERVEDELSLISTE

ERSATZTEILLISTE

SPARE PARTS LIST

LISTE DE PIÈCES

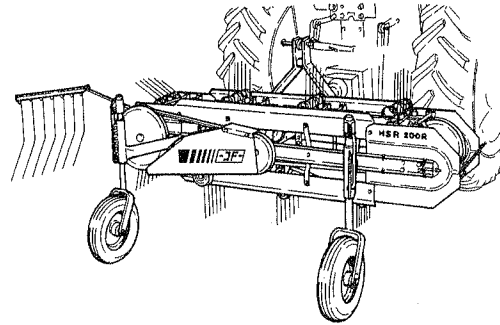

Bogen er opdelt i 4 afsnit:

1. Instruktion.
2. Nummernøgle - viser på hvilke figurer numrene findes.
3. Figur nøgle - viser på hvilke figurer delene findes.
4. Reservedelsliste.

Das Ersatzteillbuch ist in 4 Abschnitte eingeteilt:

1. Instruktion.
2. Ein Nummerschlüssel mit Angabe der jeweiligen Ersatzteilnummern.
3. Eine Figurliste mit Angabe, wo die Teile zu finden sind.
4. Eine Ersatzteilliste.

The book is divided into 4 passages:

1. Directions for use.
2. Number key showing on which figures the number can be found.
3. Figure key showing on which figures the parts can be found.
4. Spare parts list.

Le manuel est divisé en 4 sections:

1. Instruction de l'emploi.
2. Liste des numéros indiquant sur quelle figure se trouve le numéro.
3. Liste des figures indiquant sur quelle figure se trouvent les pièces.
4. Liste de pièces de rechange.

Eksempel fra reservedelslisten, af hvilket følgende oplysninger fremgår:

Ein Beispiel von der Ersatzteilliste, aus welchem folgende Aufschlüsse hervorgehen:

Example from the spare parts list with detailed information:

Exemple d'une liste de pièces détachées avec la signification des différentes colonnes:

Ejemplo de la lista de requesto de la que resultan las siguientes indicaciones:

Esimerkki varaosaluettelosta mistä seuraavat tiedot löytyvät:

Antal dele pr. maskine. Ved undersamling pr. samling.
 Anzahl Teile je Masch. Bei Untersammlungen Anzahl je Sammlung.
 States quantity of parts for one machine. In connection with under parts: quantity for the assembly.
 Quantité des pièces pour une machine. Pour les numéros décalés, la quantité indiquée est celle qui se trouve dans la pièce assemblée.
 Número de piezas por máquina. En los conjuntos indica la cantidad que lleva cada conjunto.
 Osien lukumäärä konetta kohden Alaryhmien lukumäärä.

POS.	NUMMER	ANTAL	BETEGNELSE BEZEICHNUNG	DESIGNATION DESIGNATION	HERTIL, DAZU, TO THIS, AVEC
5	3101-500x	1	mellemstykke Zwischenstück	intermediate piece bâti intermédiaire	1212-3322 M 10x30 13 1214-3123 M 10x40 2 1220-3321 M 10
6	2101-539x	1	sideplade, venstre Seitenplatte, links	side plate, left plaque latérale, gauche	1212-2126 M 8x15 11 1212-2126 M 8x15 11
7	3101-560x	1	topplade Topplatte	top plate plaque supérieur	

Standard numrenes betydning:

Die Bezeichnung der Standard-Nummern:

The meaning of the standard numbers:

Les pièces standards peuvent être identifiées au moyen des 4 premiers chiffres de leur numéro de référence:

Lista de las denominaciones de tuercas, tornillos, etc.:

Vakionumeroiden tarkoitus:

<u>1211-</u> maskinskrue Masch. Schraube machine screw vis et boulons standard divers tornillos y bulones standard div. konepultti	<u>1219-</u> vinge el. unbrako el. plovskrue Unbraco-Schraube wing screw, unbraco screw, plough screw vis spéciales tornillo-Unbraco siipi, unbrako tai aurapultti	<u>1255-</u> låseringe Seegeringe lock ring circlips anillos elásticos lukitusrengas
<u>1212-</u> sætskrue Setzschraube set screw vis et boulons standard divers tornillos y bulones standard div. kierrepultti	<u>1220-</u> møtrikker Mutter nut écrous tuercas mutterit	<u>1313-</u> smørenippel Druckschmiernippel grease nipple graisseurs engeasadores voitelunippa
<u>1213-</u> stålsetzkrue Stahlsetzschraube steel set screw vis et boulons standard divers tornillos y bulones standard div. teråskierrepultti	<u>1242-</u> tand- eller skråskiver Zahn oder Federscheiben toothed or slant disk rondelles spéciales muelles especiales hammastetut tai vinoaluslevyt	<u>1317-</u> dele for hydraulik Teile f. Hydraulik parts for hydraulics pièces pour hydraulique piezas para hidráulico hydrauliikan osa
<u>1214-</u> stålskrue Stahlschraube steel screw vis et boulons standard divers tornillos y bulones standard div. teråspultti	<u>1251-</u> spændestifter Spannstifte special pin goupilles mécaniques pasadores elásticos híhnapyörien lukitusokat	<u>1332-</u> simmerringe Simmerringe snap ring joints d'étanchéité retenes simmerrengas
<u>1215-</u> brædeskrue Schloss-Schraube carriage bolt vis et boulons standard divers tornillos y bulones standard div. pyöreäkantainen puupultti	<u>1253-</u> nitter Nieten rivet rivets remaches niitit	<u>1340-</u> dele f. kraftoverføring <u>1341-</u> Teile f. Gelenkwelle <u>1342-</u> parts f. P.T.O. shaft pièces d'arbres à cardans parte eje cardan voimansiiron osa
<u>1216-</u> rundhovedet el. undersænket skrue Masch. Schraube R/H = Ø round headed or countersunk screw vis et boulons standards divers tornillos y bulones standard div. pyöreäkantainen allesuunnattu pultti	<u>1254-</u> fjeder- eller ringsplitter Feder- oder Ringsplinte spring- or ring pin goupilles resortes jousi tai rengassokat	

NUMMER	FIG.	POS.	NUMMER	FIG.	POS.	NUMMER	FIG.	POS.
1321-1301	4	11	3191-083x	4	4			
1322-1101	4	12	084x	4	3			
1323-1102	4	13	404x	4	10			
9031	4	14	3192-001A	2	19			
9046	4	15	003x	1	18			
1329-0101	4	9	007x	2	2			
1331-2103	2	5	009x	1	16			
3102	2	12		2	22			
	4	16	010A	1	9			
1361-6101	2	16	012x	1	4			
6102	2	16	016x	2	17			
1399-0153	4	1	025x	1	5			
1413-1301	2	20	176x	1	14			
3101	1	3	400B	2	18			
1433-0397	1	7	414x	1	17			
0398	1	6	418x	2	21			
0399	1	19	419x	2	1			
2126-032x	4	2	421x	1	2			
2191-130x	4	19	3193-155x	2	8			
138x	4	20	3194-001x	3	5			
201x	4	17	3199-003x	4	7			
2192-023x	2	6	4190-0411	4	5			
024x	2	3						
056x	1	15						
057x	1	21						
058x	1	20						
059x	2	7						
155x	2	13						
159x	1	8						
168x	2	4						
169x	1	11						
170A	1	10						
171A	1	15						
172x	1	12						
181A	1	13						
2193-003A	2	9						
005B	2	14						
154x	2	11						
156x	2	10						
2194-003C	3	1						
004C	3	2						
018x	2	15						
151A	3	5						
152A	3	4						
154x	3	2						
155x	3	3						
2199-206x	4	6						
207x	4	8						
3191-005x	4	18						
010B	1	1						
014G	1	1						

Fig. 1

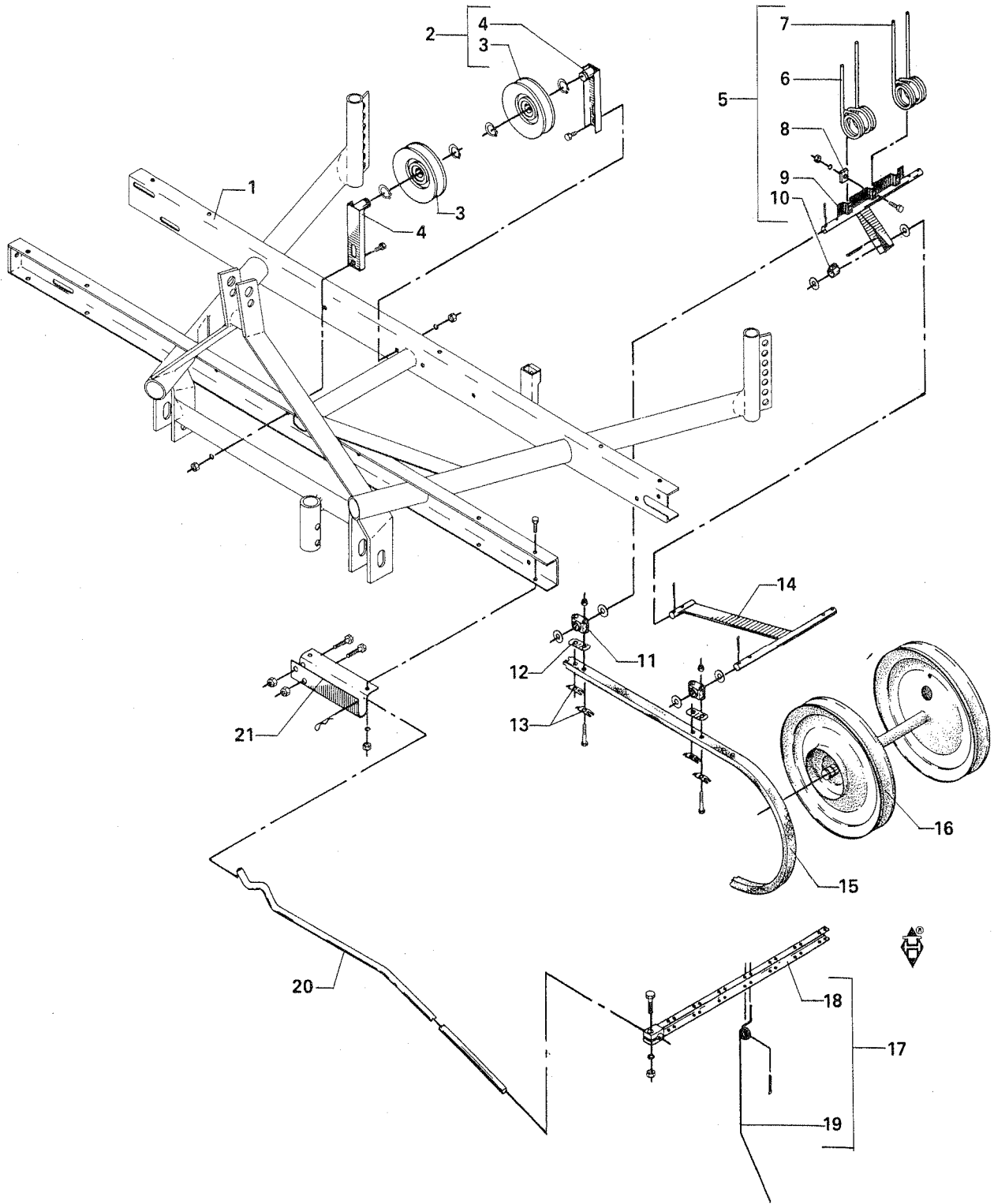

POS.	NUMMER	200R	240R	BETEGNELSE	BEZEICHNUNG	DESIGNATION	HERTIL,DAZU,TO THIS,A CECI:
1	3191-014G	1	-	Hovedramme	Hauptrahmen	Main frame	
	3191-010B	-	1	Hovedramme	Hauptrahmen	Main frame	
						Chassis	
2	3192-421x	2	2	Remstrammer samlet	Riemenspanner gesammelt	Belt tightener assembling	
						Tendeur de courroie assemblé	
3	1413-3101	1	1	Strammerulle	Spannrolle	Tightening roller	
						Galet de tendeur	
4	3192-012x	1	1	Holder for remstrammer	Halterung f. Riemenspanner	Support for belt tightener	
						Support de tendeur de courroie	
5	3192-025x	9	11	Fjederaksel med styr samlet	Zinkenwelle gesammelt	Shaft for tine assembling	
						Ressort d'arbre assemblé	
6	1433-0398	1	1	Sidetryksfjeder, kort	Federzinken, kurz	Lateral thrust spring, short	
						Côte de ressort de pression court	
7	1433-0397	2	2	Sidetryksfjeder	Federzinken	Lateral thrust spring	
						Côte de ressort de pression	
8	2192-159x	3	3	Skive for sidetryksfjeder	Scheibe f. Federzinken	Disc for lateral thrust spring	1213-2223 M 8x25
						Rondelle pour côte de ressort	1220-2123 M 8
						de pression	
9	3192-010A	1	1	Fjederaksel	Zinkenwelle	Shaft for tines	
						Ressort d'arbre	
10	2192-170A	1	1	Nylonbøsning	Nylon Buchse	Nylon bush	
						Douille de nylon	
11	2192-169x	36	44	Nylonleje	Nylonlager	Nyloc bearing	1219-0601 M 8x65
						Roulement de nylon	1220-2321 M 8
12	2192-172x	36	44	Underlag, bredt	Anlageplatte, breit	Support plate, broad	
						Plaque de support large	
13	2192-181A	72	88	Underlag	Anlageplatte	Support plate	
						Plaque de support	
14	3192-176x	9	11	Fjederstyr	Steuerung f. Zinkenwelle	Guide for tines	
						Guide de ressort	
15	2192-171A	2	-	Kilerem	Keilriemen	V-belt	
						Courroie	
	2192-056x	-	2	Kilerem	Keilriemen	V-belt	
						Courroie	
16	3192-009x	1	1	Drevaksel	Antriebswelle	Gearshaft	
						Arbre de pignon	
17	3192-414x	1	1	Skårsamler kpl.	Schwadsammler kpl.	Swath collector cpl.	
						Grille d'andainage cpl.	
18	3192-003x	1	1	Rør for skårsamler	Rohr f. Schwadsammler	Tube for swath collector	1214-4125 M 12x45
						Tuyau de grille d'andainage	1220-4121 M 12
19	1433-0399	7	7	Fjeder for skårsamler	Feder f. Schwadsammler	Tine for swath collector	
						Ressort de grille d'andainage	
20	2192-058x	1	1	Bøjle for skårsamler	Bügel f. Schwadsammler	Hoop for swath collector	
						Etrier de grille d'andainage	
21	2192-057x	1	1	Holder for skårsamler	Halterung f. Schwadsammler	Support for swath collector	1214-4126 M 12x45
						Support de grille d'andainage	1220-4321 M 12
							1254-2101 4 mm

Fig. 2

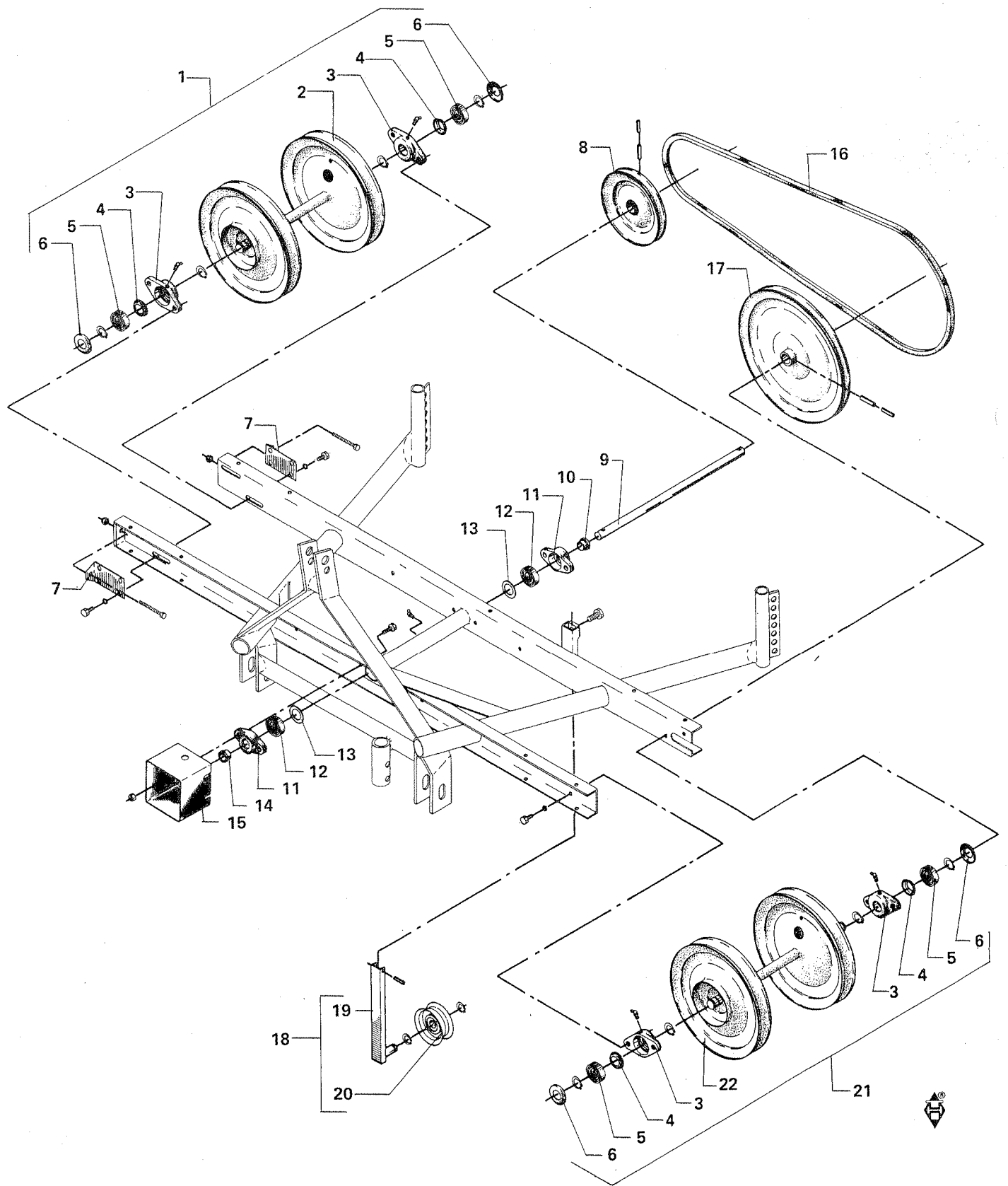

POS.	NUMMER	200R	240R	BETEGNELSE	BEZEICHNUNG	DESIGNATION	HERTIL, DAZU, TO THIS, A CECI:	
1	3192-419x	1	1	Aksel samlet, løs Welle gesammelt, los		Shaft assembling, loose Arbre assemblé desserré		
2	3192-007x	1	1	Aksel Welle		Shaft Arbre		
3	2192-024x	2	2	Lejehus Lagergehäuse		Bearing housing Boîte de roulement	1313-2401 H2R 1213-4223 M 12x25	1 2
4	2192-168x	2	2	Tætningsring Dichtungsring		Tightening ring Anneau d'étanchéité		
5	1331-2103	2	2	Kugleleje 6006 Kugellager 6006		Ball bearing 6006 Roulement 6006	1255-3201 U 30	4
6	2192-023x	2	2	Afstandsring Distanzring		Distance ring Anneau d'espacement		
7	2192-059x	2	2	Spændeplade Spannplatte		Tightening plate Plaque de serrage	1213-3724 M 10x90 1220-3321 M 10	1 1
8	3193-155x	1	1	Kileremskive B 200 Keilriemenscheibe B 200		Pulley B 200 Poulie B 200	1251-4301 6x40 1251-6301 10x40	1 1
9	2193-003A	1	1	Aksel Welle		Shaft Arbre		
10	2193-156x	1	1	Bøsning Buchse		Bush Douille		
11	2193-154x	2	2	Lejehus, ovalt Lagergehäuse, ovalet		Bearing housing, oval Palier ovale		
12	1331-3102	2	2	Kugleleje Kugellager		Ball bearing Roulement		
13	2192-155x	2	2	Skærplade Schutzplatte		Guard plate Plaque de protection		
14	2193-005B	1	1	Afstandsboøsning Distanzbuchse		Distance bush Douille d'espacement		
15	2194-018x	1	1	Skærm for kraftoverføring Schutz f. Gelenkwelle		Guard for P.T.O. Protection d'arbre à cardans		
16	1361-6101	1	-	Kilerem Keilriemen		V-belt Courroie		
	1361-6102	-	1	Kilerem Keilriemen		V-belt Courroie		
17	3192-016x	1	1	Kileremskive B 387 Keilriemenscheibe B 387		Pulley B 387 Poulie B 387	1251-4302 6x45 1251-6302 10x45	1 1
18	3192-400B	1	1	Remstrammer kpl. Riemenspanner kpl.		Belt tightener cpl. Tendeur de courroie cpl.		
19	3192-001A	1	1	Remstrammerarm Riemenspannerarm		Belt tightener arm Bras de tendeur de courroie	1251-4402 6x55	1
20	1413-1301	1	1	Strammerulle Spannrolle		Tightening roller Gilet de tendre	1255-2203 U 25	2
21	3192-418x	1	1	Drevaksel samlet Antriebswelle gesammelt		Driving shaft assembling Arbre de transmission assemblé		
22	3192-009x	1	1	Drevaksel Antriebswelle		Driving shaft Arbre de transmission		

+ pos. 3 - 4 - 5 - 6.

Fig. 3

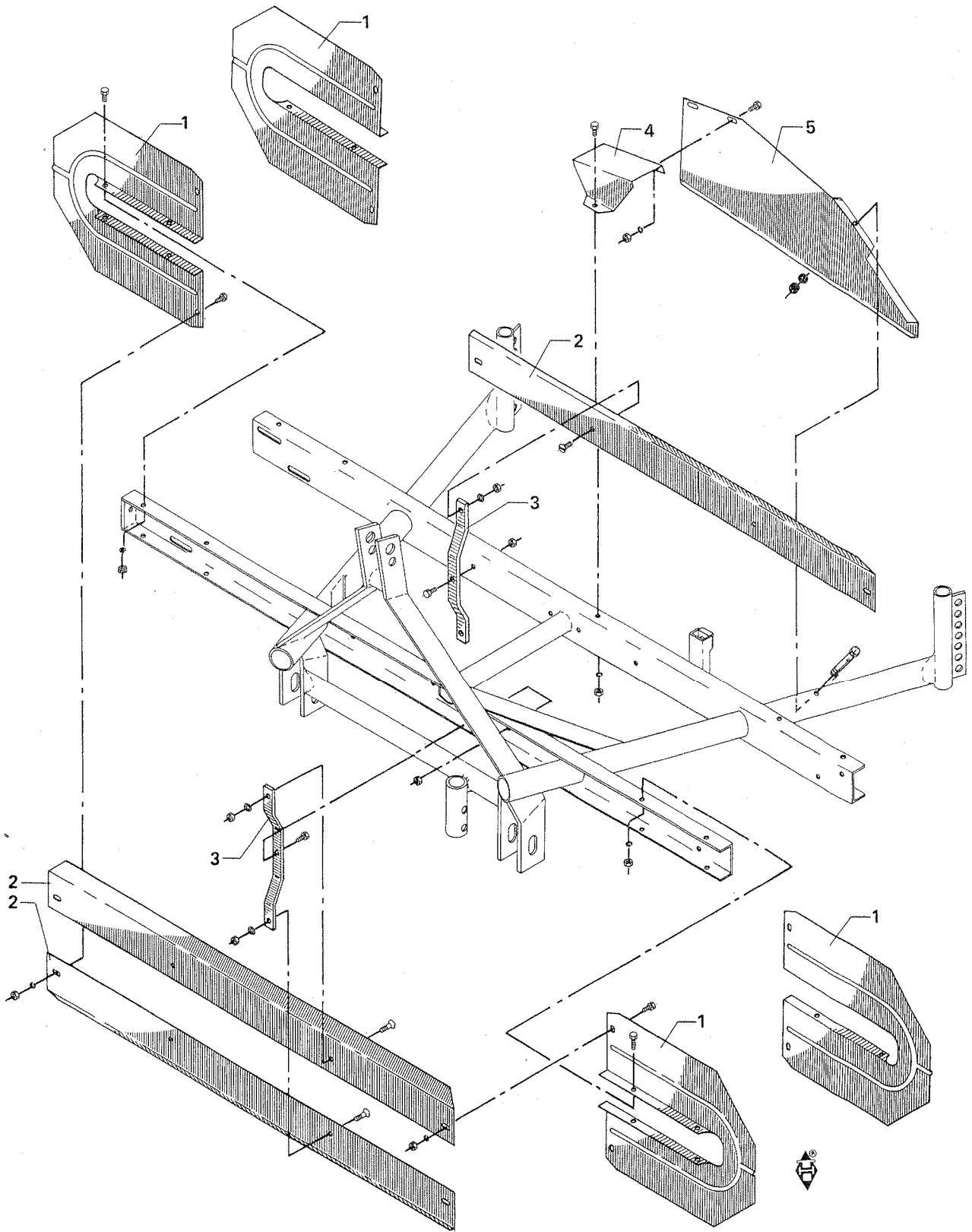

POS.	NUMMER	200R	240R	BETEGNELSE	BEZEICHNUNG	DESIGNATION	HERTIL, DAZU, TO THIS, A CECI:	
1	2194-003C	4	4	Skærm Schutz		Guard Protection	1212-3126 M 10x15	8
							1212-3222 M 10x20	14
							1220-3122 M 10	22
2	2194-004C	4	-	Skærm Schutz		Guard Protection	1216-3242 M 10x20	2
							1220-3122 M 10	2
	2194-154x	-	4	Skærm Schutz		Guard Protection	1216-3242 M 10x20	2
							1220-3122 M 10	2
3	2194-155x	4	4	Skærmstiver, dobbelt Schutzstrebe, dobbelt		Support for guard, double Branche de support double	1212-3223 M 10x25	1
							1220-3121 M 10	1
4	2194-152A	1	1	Skærmholder Schutzhalterung		Support for guard Support de protection	1212-3222 M 10x20	1
							1220-3121 M 10	1
5	2194-151A	1	-	Skærm Schutz		Guard Protection	1211-3324 M 10x75	1
							1212-3126 M 10x15	2
							1220-3122 M 10	3
	3194-001x	-	1	Skærm Schutz		Guard Protection	1211-3324 M 10x75	1
							1212-3126 M 10x15	2
							1220-3122 M 10	3

Fig. 4

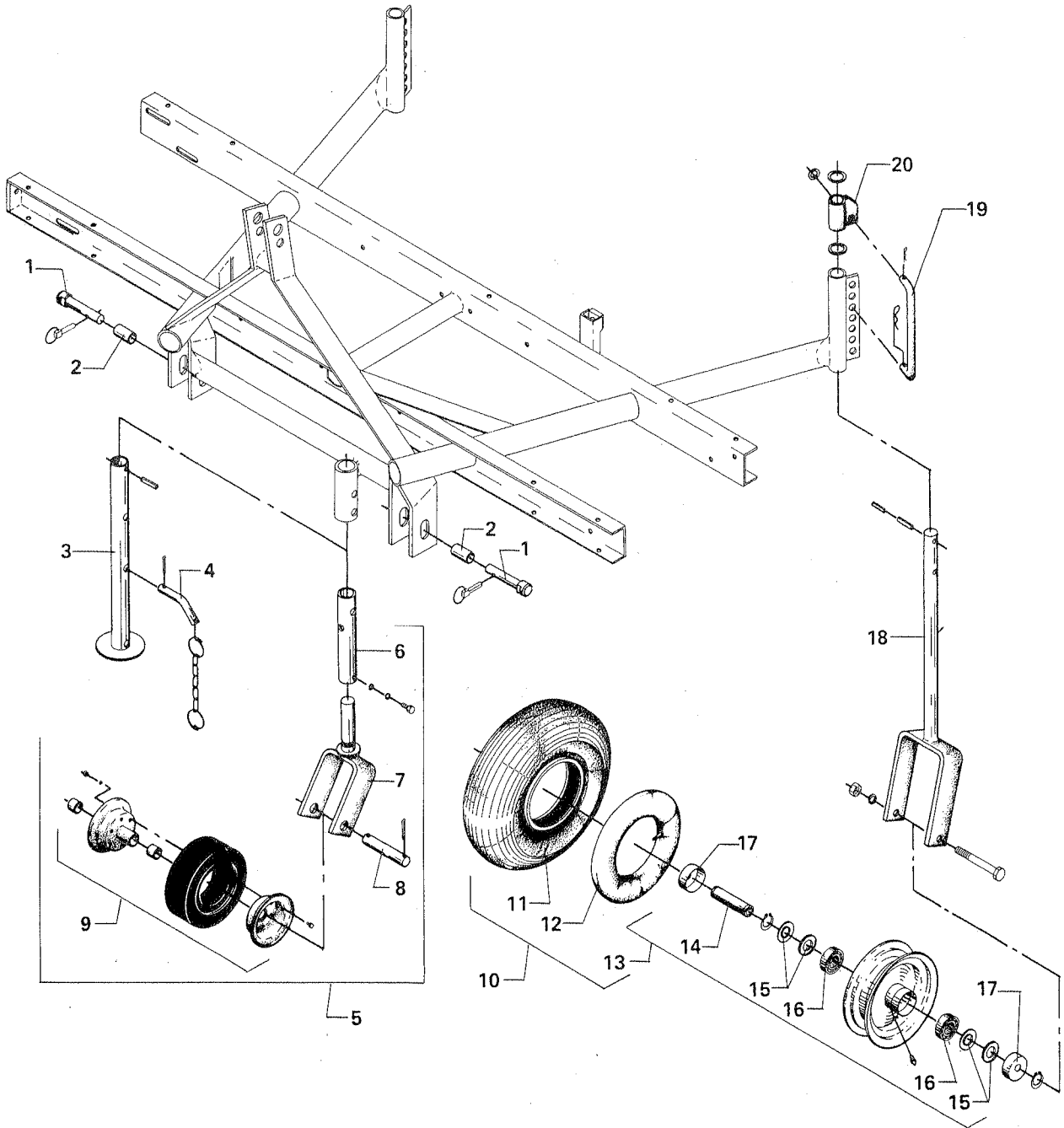

POS.	NUMMER	200R	240R	BETEGNELSE BEZEICHNUNG	DESIGNATION	HERTIL, DAZU, TO THIS, A CECI:	
1	1399-0153	2	2	Tap for trækarm Zapfen f. Schwingachse	Dowel for drawbar Cheville de bras de transmission	1254-4201 4 mm	1
2	2126-032x	2	2	Bøsning for tap Buchse f. Zapfen	Bush for dowel Douille de cheville		
3	3191-084x	1	1	Støtteben Abstellstütze	Castor jack Béquille		
4	3191-083x	1	1	Tap for støtteben kpl. Zapfen f. Abstellstütze	Dowel for castor jack Cheville de béquille		
5	* 4190-0411	1	1	Støttehjul kpl. Stützrad kpl.	Castor wheel cpl. Roue support cpl.		
6	2199-206x	1	1	Mellemrør Zwischenrohr	Intermediate tube Tuyau intermédiaire	1213-3124 M 10x12	1
7	3199-003x	1	1	Hjulgaffel Radgabel	Wheel fork Mâchoire de roue		
8	2199-207x	1	1	Aksel Welle	Shaft Arbre		
9	1329-0101	1	1	Hjul kpl. med massiv dæk Rad kpl. mit Vollreifen	Wheel kpl. with solid tyre Roue cpl. avec pneu plein		
10	3191-404x	2	2	Hjul kpl. Rad kpl.	Wheel cpl. Roue cpl.		
11	1321-1301	1	1	Dæk Reifen	Tyre Pneu		
12	1322-1101	1	1	Slange Schlauch	Tube Chambre à air		
13	1323-1102	2	2	Nav samlet Nabe gesammelt	Hub assembling Moyeu assemblé	1323-9347	1
14	1323-9031	1	1	Aksel Welle	Shaft Arbre	1255-2203 U 25	2
15	1323-9046	2	2	Tætningslamel Dichtungslamelle	Tightening slat Lamelle d'étanchéité		
16	1331-3102	2	2	Leje 6205 Lager 6205	Bearing 6205 Roulement 6205		
17	2191-201x	4	4	Skærmpåde Schutzplatte	Baffle plate Plaque protectrice		
18	3191-005x	2	2	Hjulgaffel Radgabel	Wheel fork Mâchoire de roue	1211-5622 M 16x170 1251-5304 8,45	1 4
19	2191-130x	2	2	Forbindelsesstang Verbindungsstange	Connection rod Bielle	1254-2101 4 mm	1
20	2191-138x	2	2	Trykleje Drucklager	Thrust bearing Palier de poussé		

* Ekstraudstyr - Extra equipment - Ekstrausrüstung - Equipement supplémentaire

Fig. 5

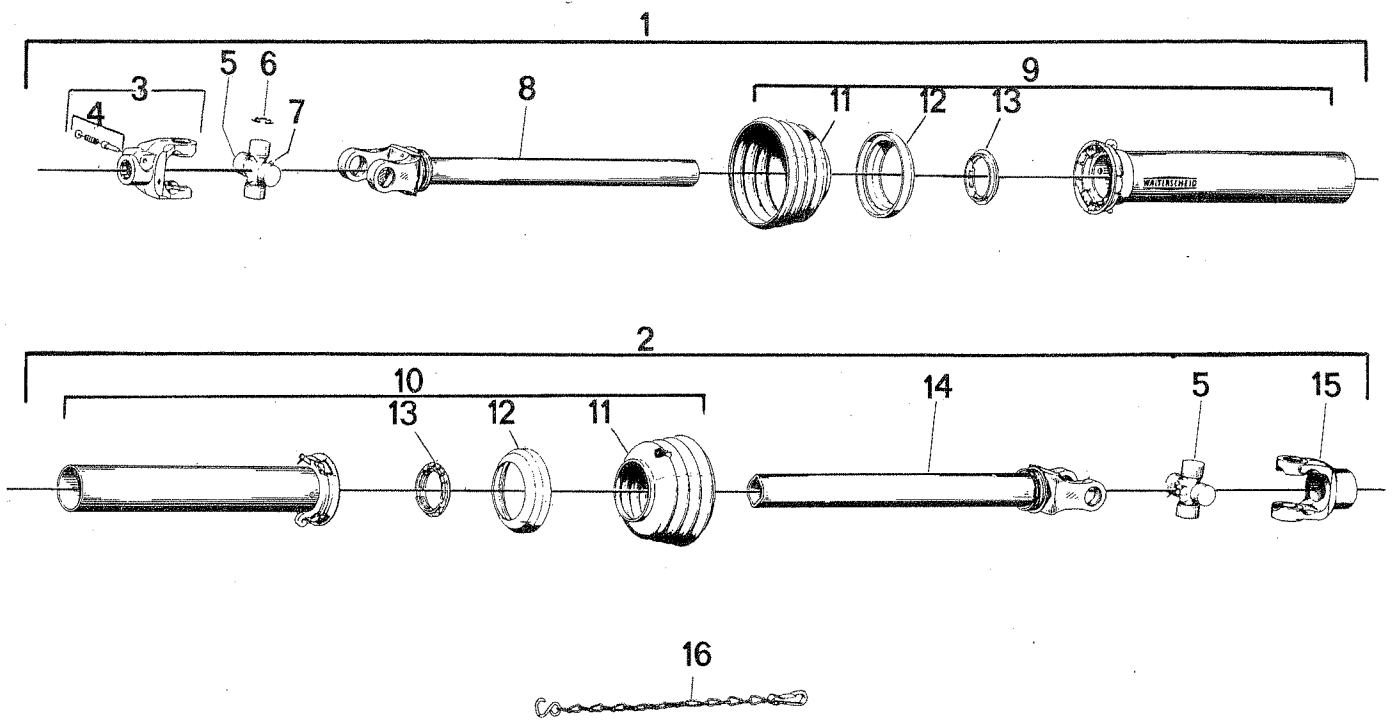

POS.	-JF-NUMMER	W.NUMMER	BETEGNELSE BEZEICHNUNG	DESIGNATION	ANTAL
1	1340-0004	-	Forreste del kpl. Vord. Teil kpl.	Front part cpl. Partie avant cpl.	1
2	1340-0052	-	Bageste del kpl. Hint. Teil kpl.	Rear part cpl. Partie arri�re cpl.	1
3	1341-9001	10.10.00	Koblingsgaffel samlet 1 3/8" Kupplungsgabel gesammelt 1 3/8"	Coupling fork assembling 1 3/8" Machoire assembl� 1 3/8"	1
4	1341-9523	Agraset 101	L�sestift kpl. Schiebstift kpl.	Lock pin cpl. Cheville d'arr�t cpl.	1
5	1341-9151	10.01.00	Kryde kpl. Kreuzgarniture kpl.	Centre cross cpl. Croisillon cpl.	2
6	1341-9172	62.02.00	Sikringsring Sicherungsring	Securing ring Circlip	8
7	1341-9187	63.22.01	Sm�renippel Schmiernippel	Grease nipple Graisseur	2
8	1340-0135	10.99.14	Gaffel med profilr�r Gabel mit Profilrohr	Fork with profile tube Fourche avec tube profile	1
9	1342-2942	85.005	Udv. beskyttelsesr�r Aussenschutzrohr	Outer Protection tube Tube protection ext�rieur	1
10	1342-2992	85.004	Indv. beskyttelsesr�r Innenschutzrohr	Inner Protection tube Tube protection int�rieur	1
11	1341-9321	85.05.04	Plastisk�rm Schutztrichter	Plastic cone Protection plastique	2
12	1341-9632	83.10.03	Forst�rkningsring St�tzring	Reinforcing collar Bague de renfort	2
13	1341-9617	83.09.00	Ring Ring	Ring Anneau	2
14	1340-0191	10.99.15	Gaffel med profilr�r Gabel mit Profilrohr	Fork with profile tube Fourche avec tube profile	1
15	1341-9065	10.22.133	Koblingsgaffel Kupplungsgabel	Coupling Fork Machoire	1
16	1341-9641	82.36.03	Holdek�de Haltekette	Support chain Chainette	1



Et omfattende maskinprogram
 Ein Lieferprogramm mit Zukunft
 Progress In Farm Machinery
 Un programme de machines etendu

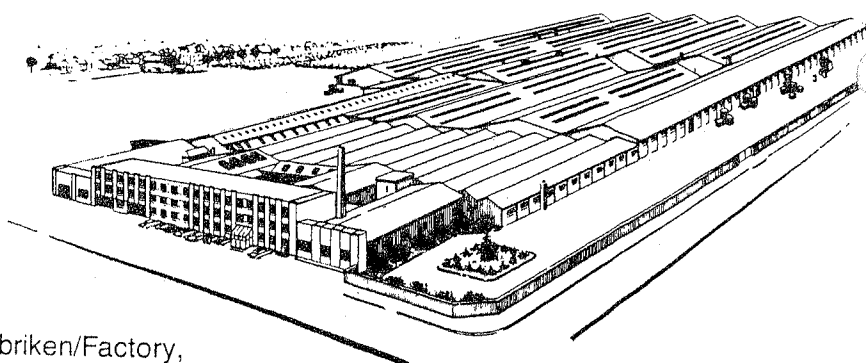
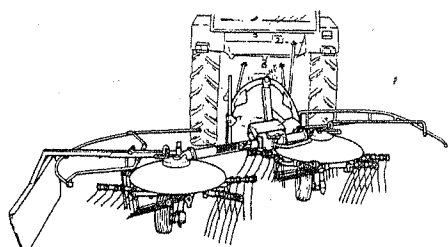
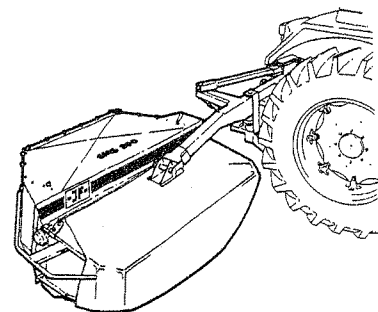
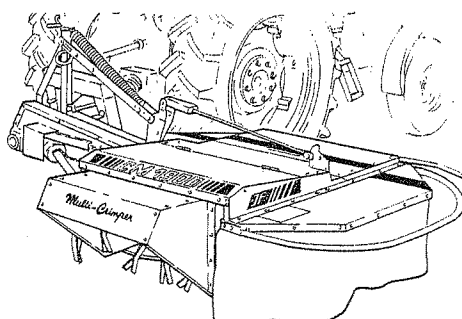
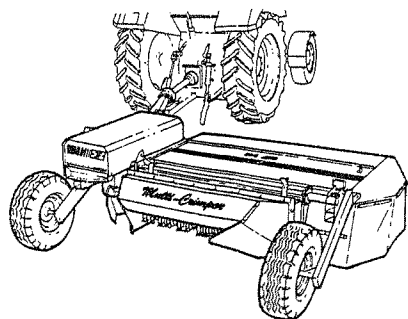

Fabriken/Factory,
 Lindeallé, Sønderborg

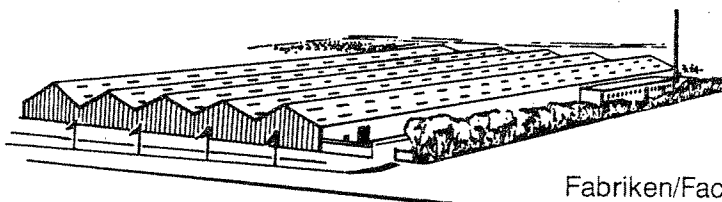
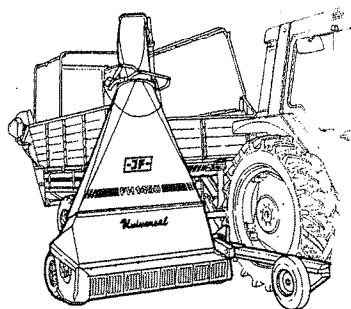

Fabriken/Factory,
 Ulkebøl, Sønderborg

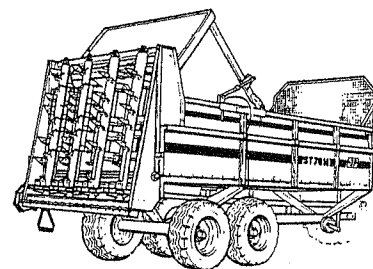
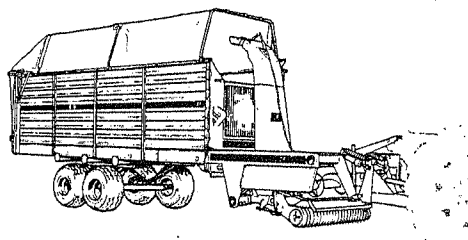
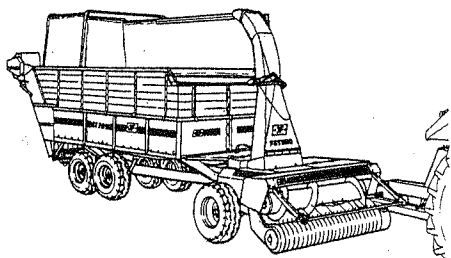

HSR 515 da-ty-en-fr 1187

PR 60-063X

JF-Fabriken - J. Freudendahl A/S
 DK-6400 Sønderborg - Danmark
 Telephone (+45) 74 12 52 52
 Telefax (+45) 74 42 58 08
 Telefax (+45) 74 42 55 41